

Artikel.-Nr.:

6020-SV-1GL

Montageanleitung.-Nr.:

MA1-00783



SCAN ME

Das Ersatzteil-Anforderungsformular finden Sie auf
The replacement parts requisition form you find on
<https://www.maeusbacher.de/ersatzteile/>

Colli 1/3

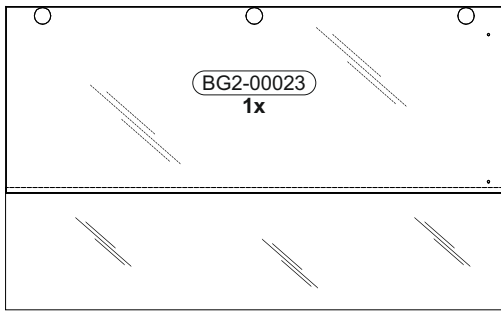

1052 x 642

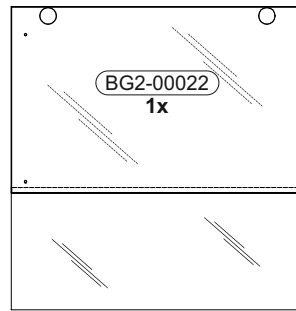

619 x 642

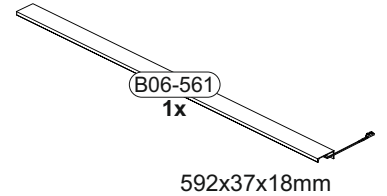

592x37x18mm

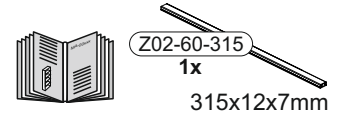

315x12x7mm

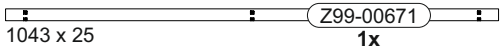

1043 x 25

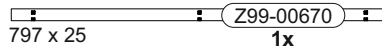

797 x 25

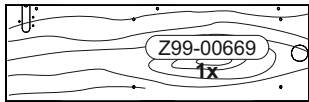

642 x 204

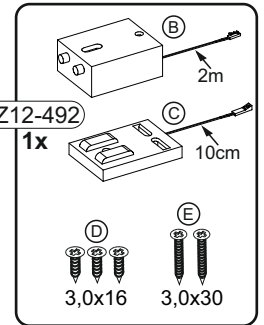
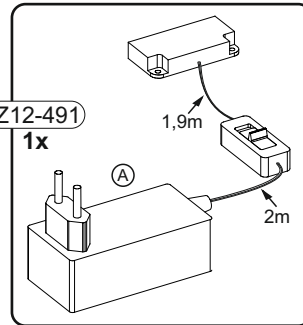
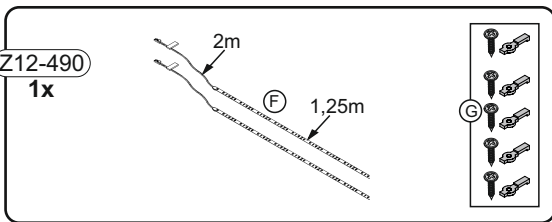

Colli 3/3

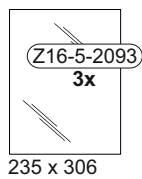

235 x 306

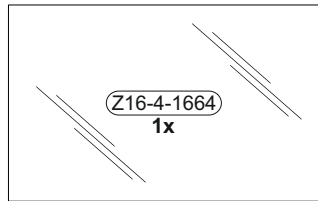

670 x 415

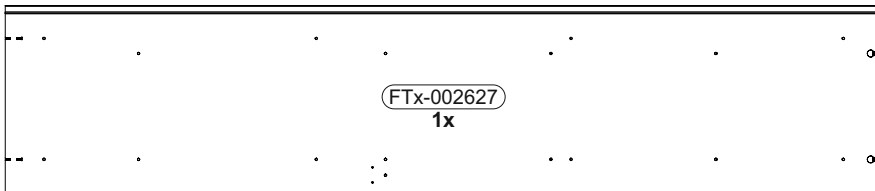

1855 x 394

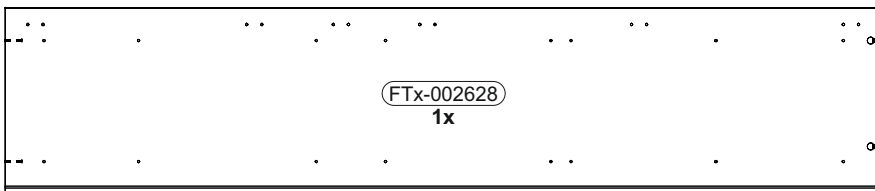

1855 x 394

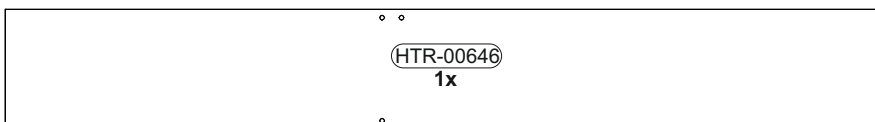

1855 x 248

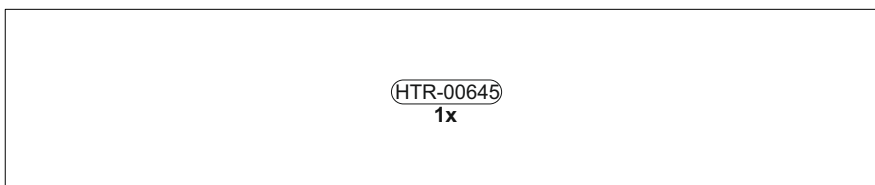

1867 x 380

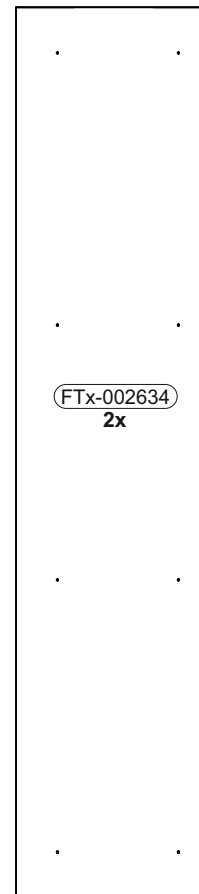

1885 x 413

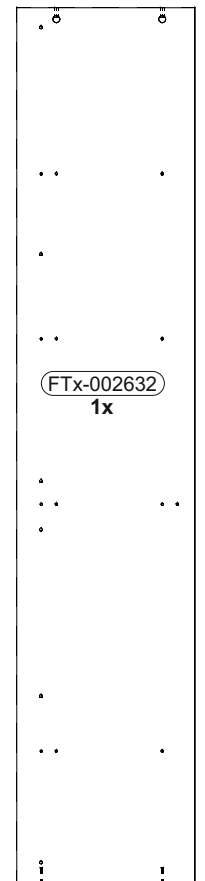

1855 x 377

BT1-00866

B01-10		B01-190		B01-200	
6x	6,3x50	16x	M4x20	17x	6,3x13
B01-30		B01-347		B01-80	
24x	3x16	16x	5x8	24x	3,5x13
B01-90		B02-160		B02-169	
6x	3,5x20	12x		6x	ø12mm
B02-90		B05-110		B08-80	
6x	6x30	12x		1x	
B02-10		B02-20			
22x	ø15x12mm	22x			

BT1-00867

B02-133		B02-144	
6x		4x	
B03-134		B05-01	
9x		8x	ø14mm
B05-130		B05-02	
1x		2x	ø20mm
B05-185			
6x			

BT1-00027

B03-01		B03-05	
6x		6x	

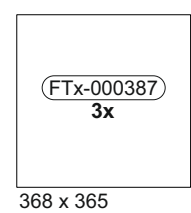
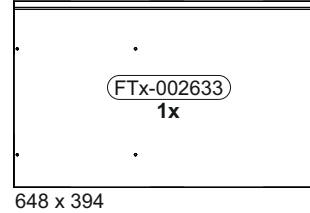
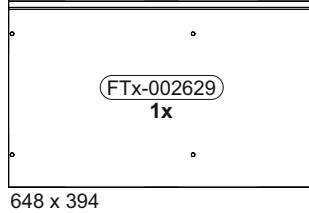
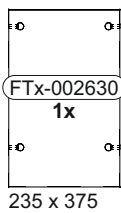
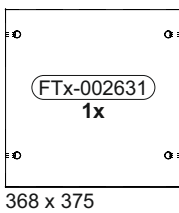
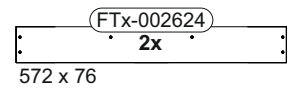
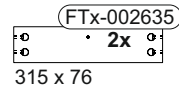

1

	B02-10		B02-20	
	8x	ø15x12mm	6x	

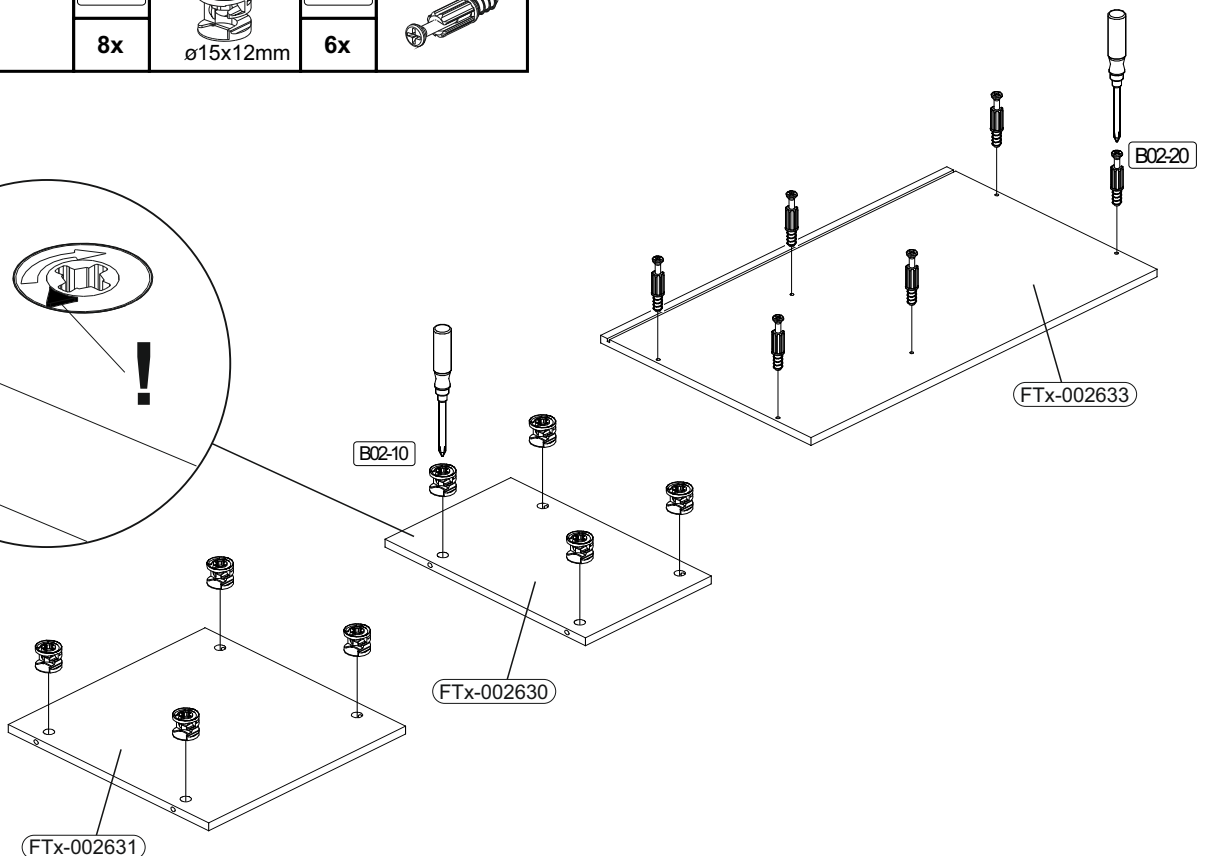
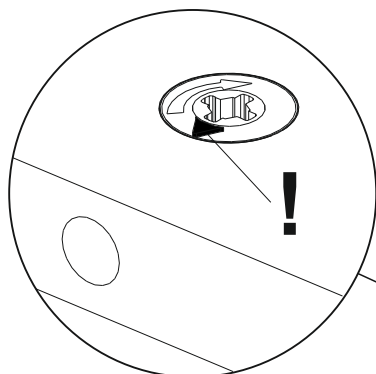

2

	B02-10		B02-160		B03-05		B02-20	
	2x	ø15x12mm	6x		6x		2x	

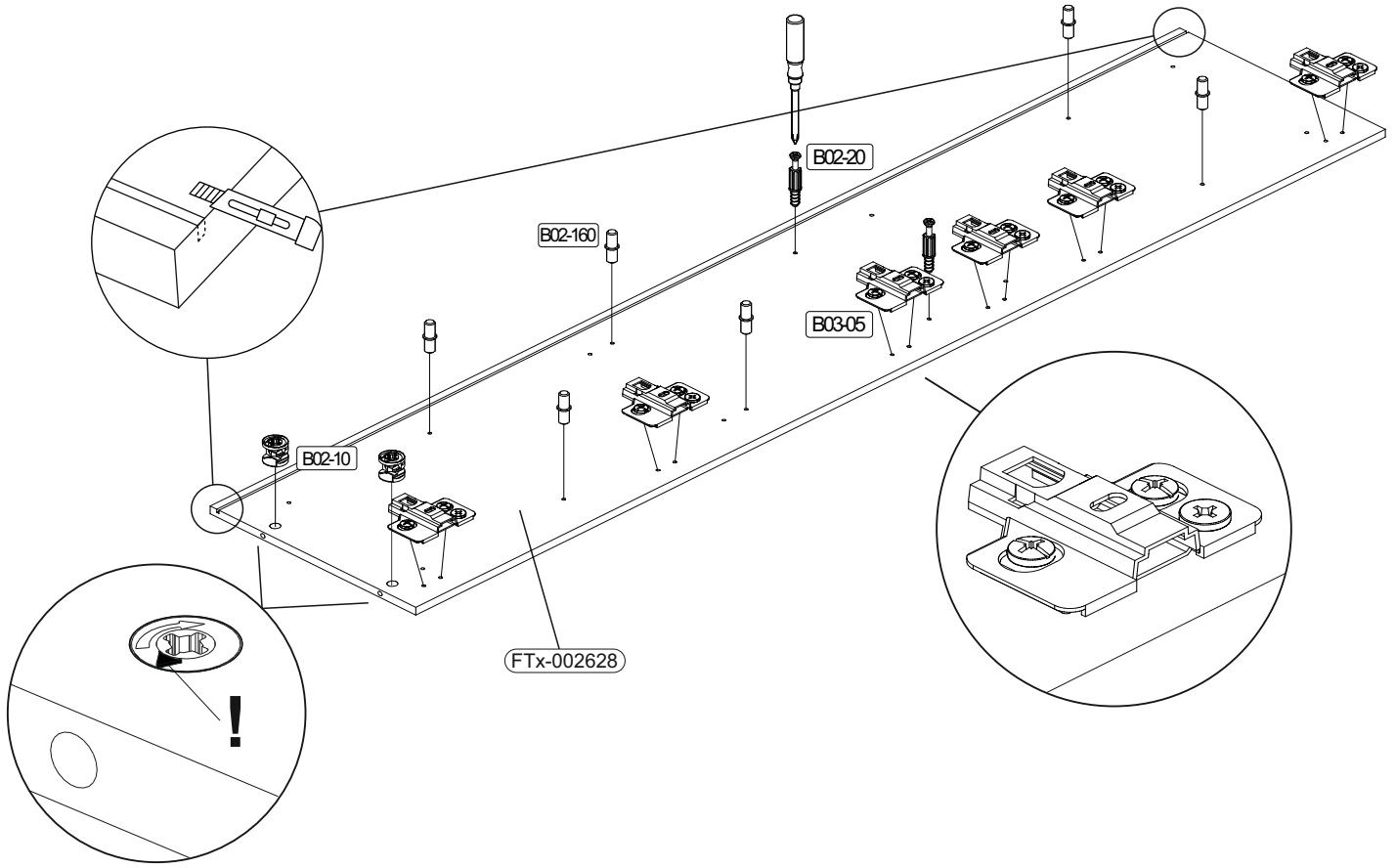

3

	B02-10		B02-20		B05-110	
	2x	ø15x12mm	2x		6x	

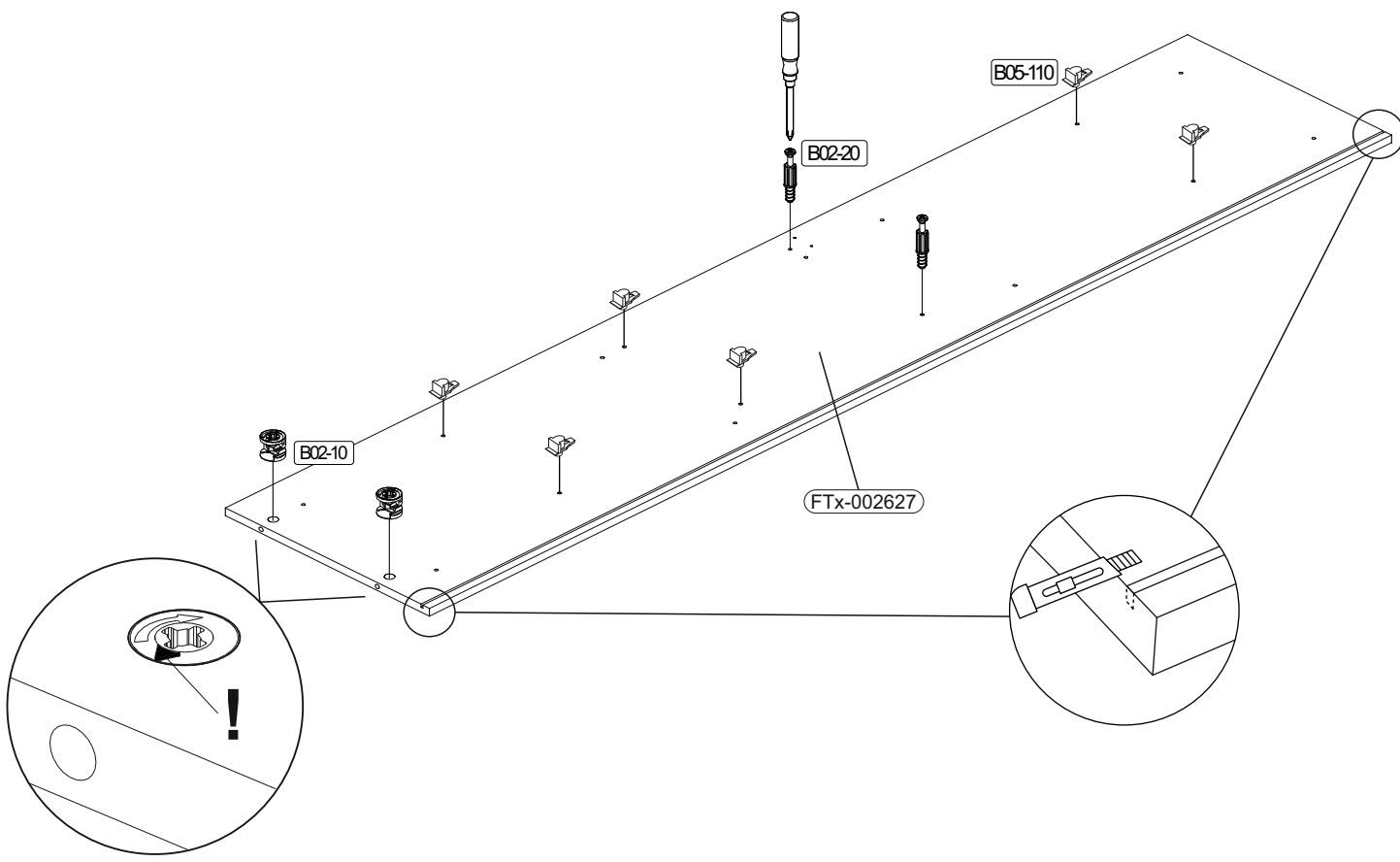

4

		B02-90 5x		6x30	B05-110 2x		B05-130 1x		B02-20 4x		B02-160 4x	
											B02-10 2x	
												ø15x12mm

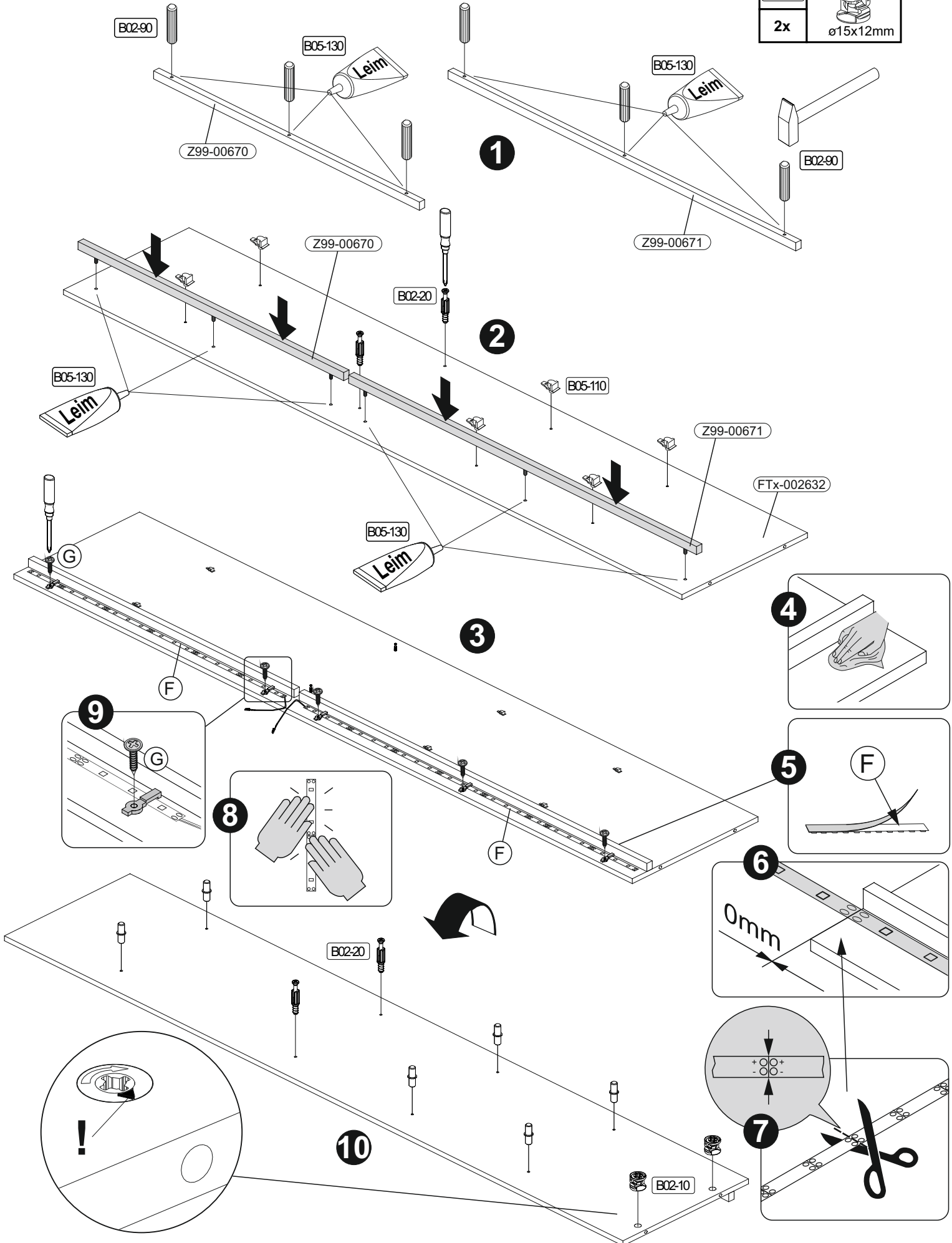

1

2

3

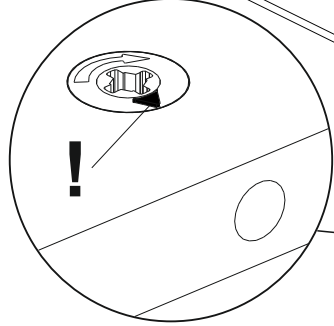
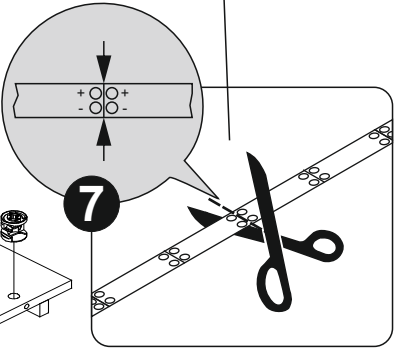
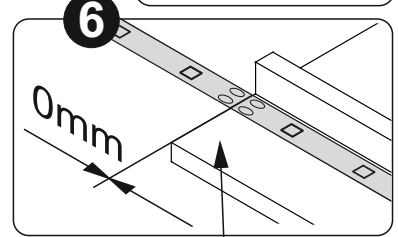
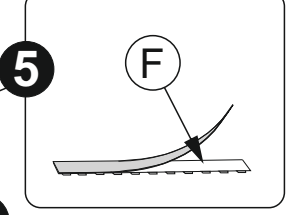
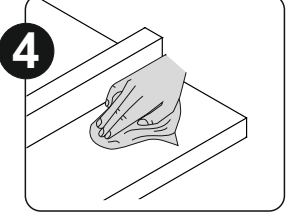
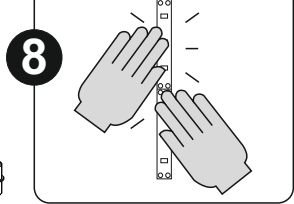
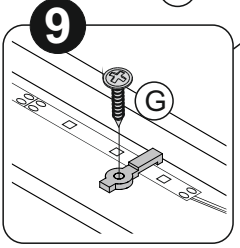

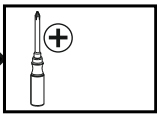
5 

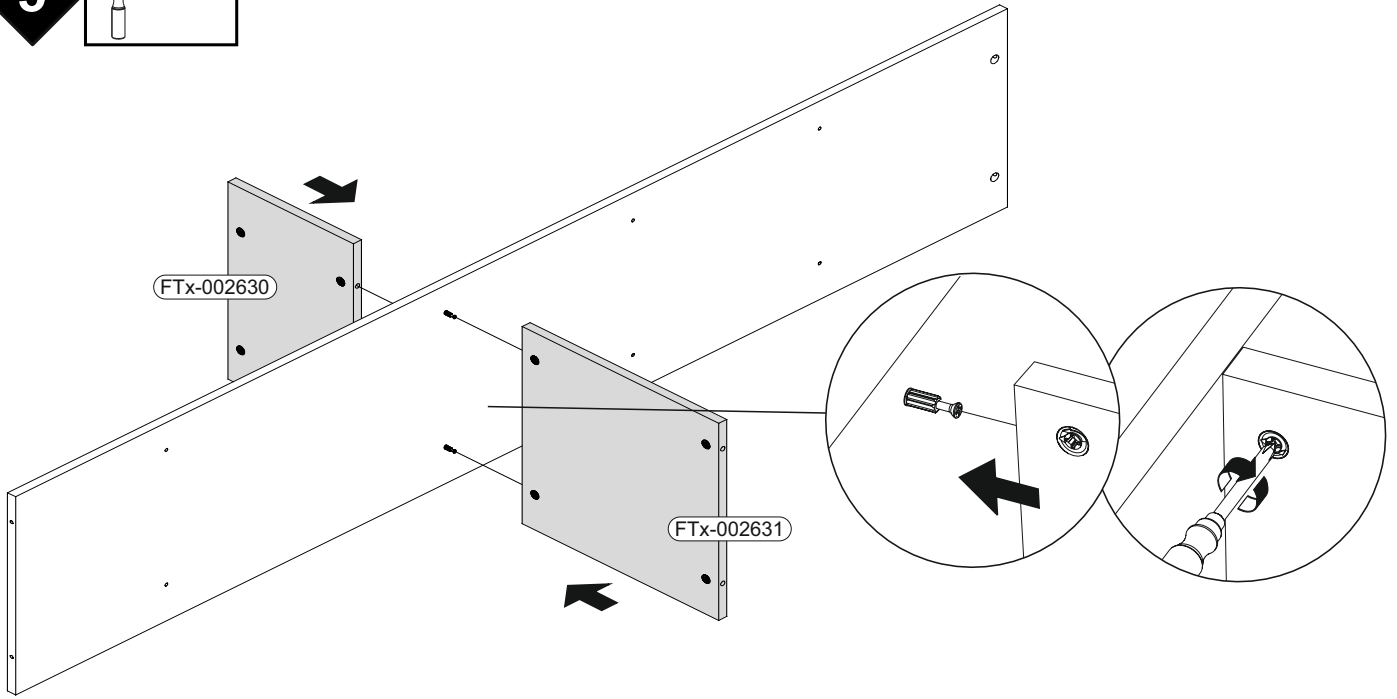

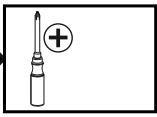
6 

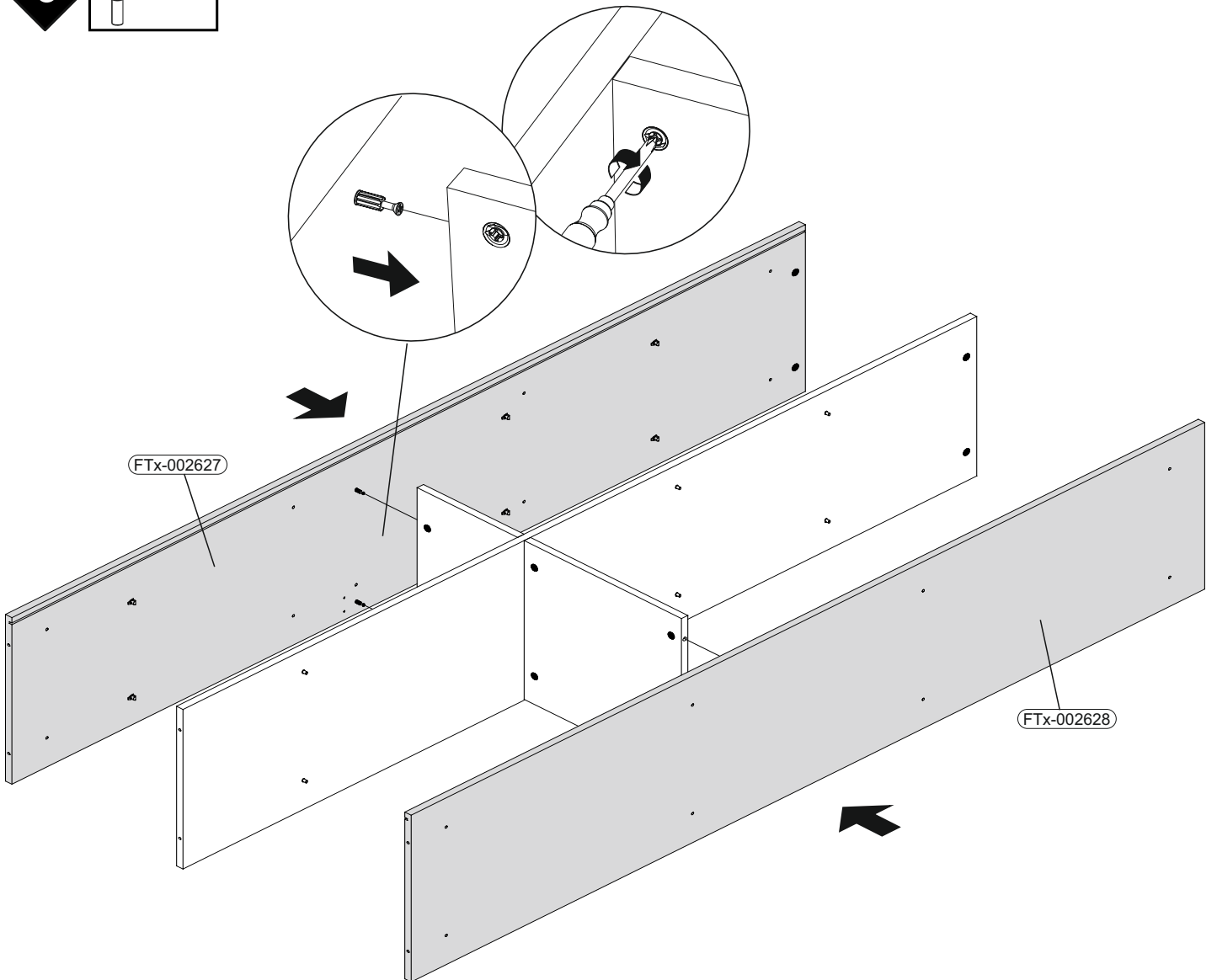

7

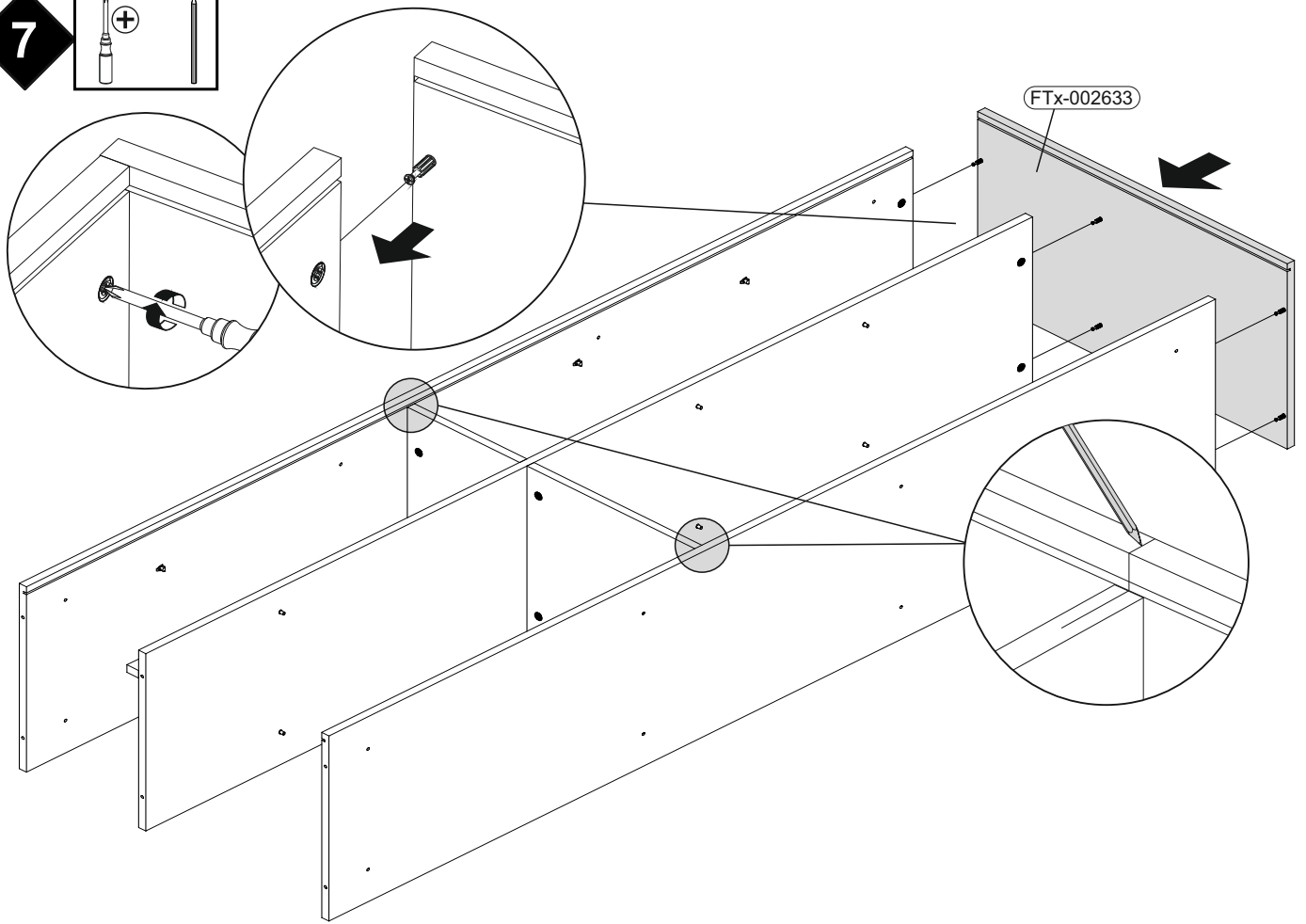
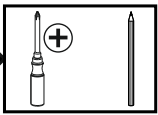

8

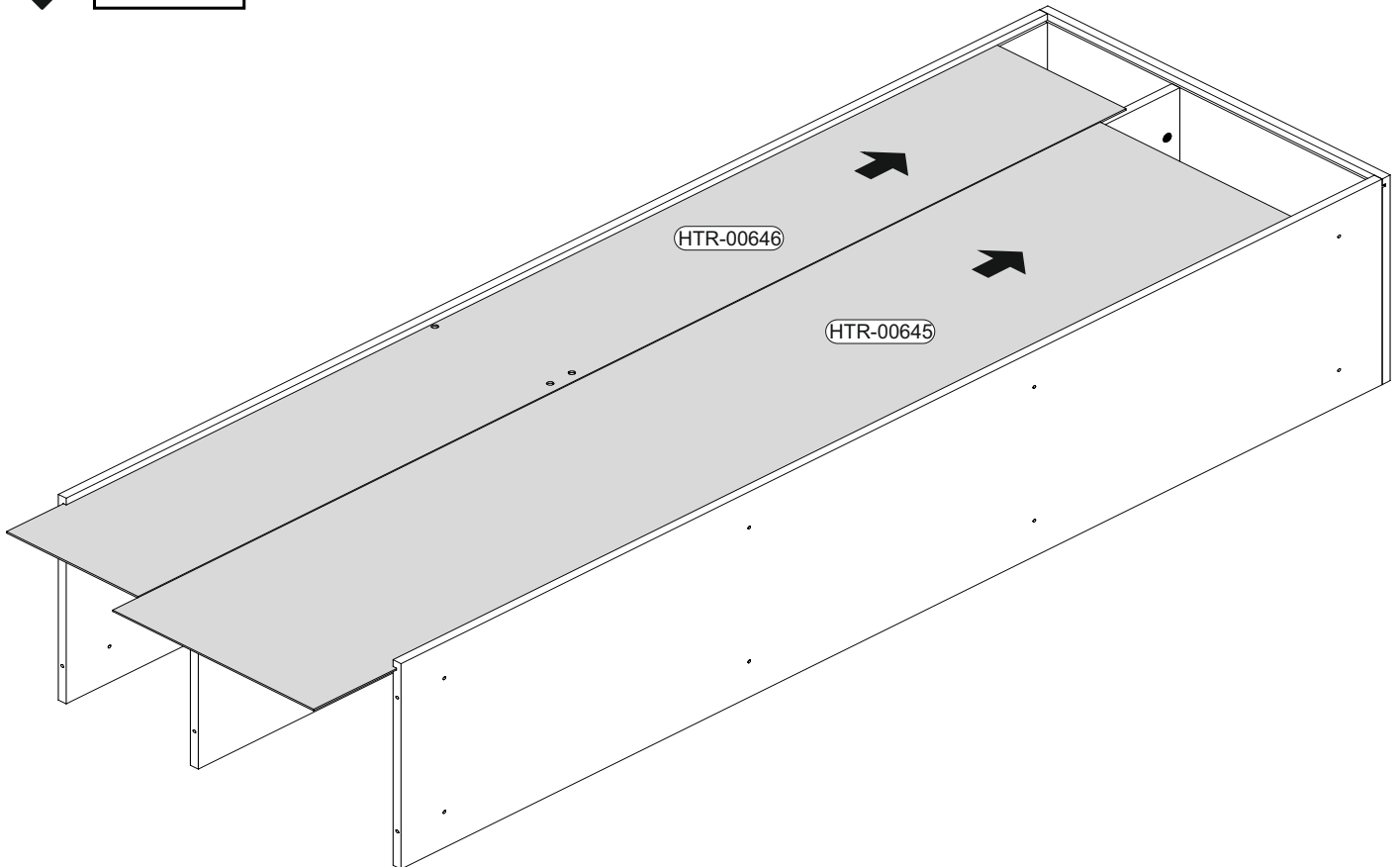

9

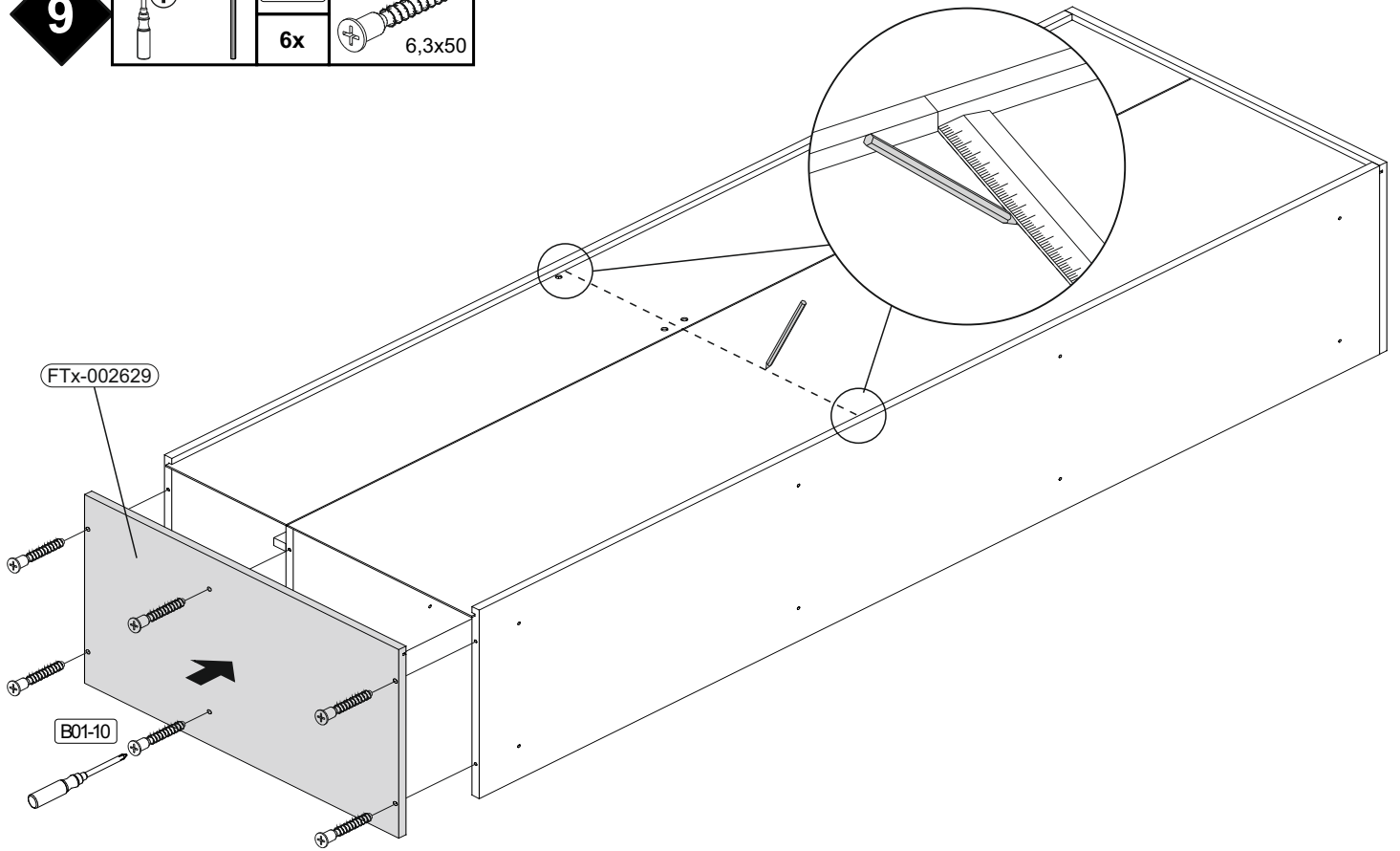
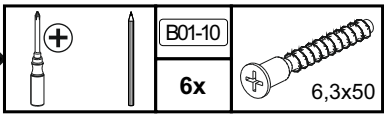



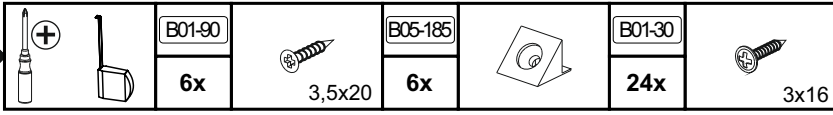



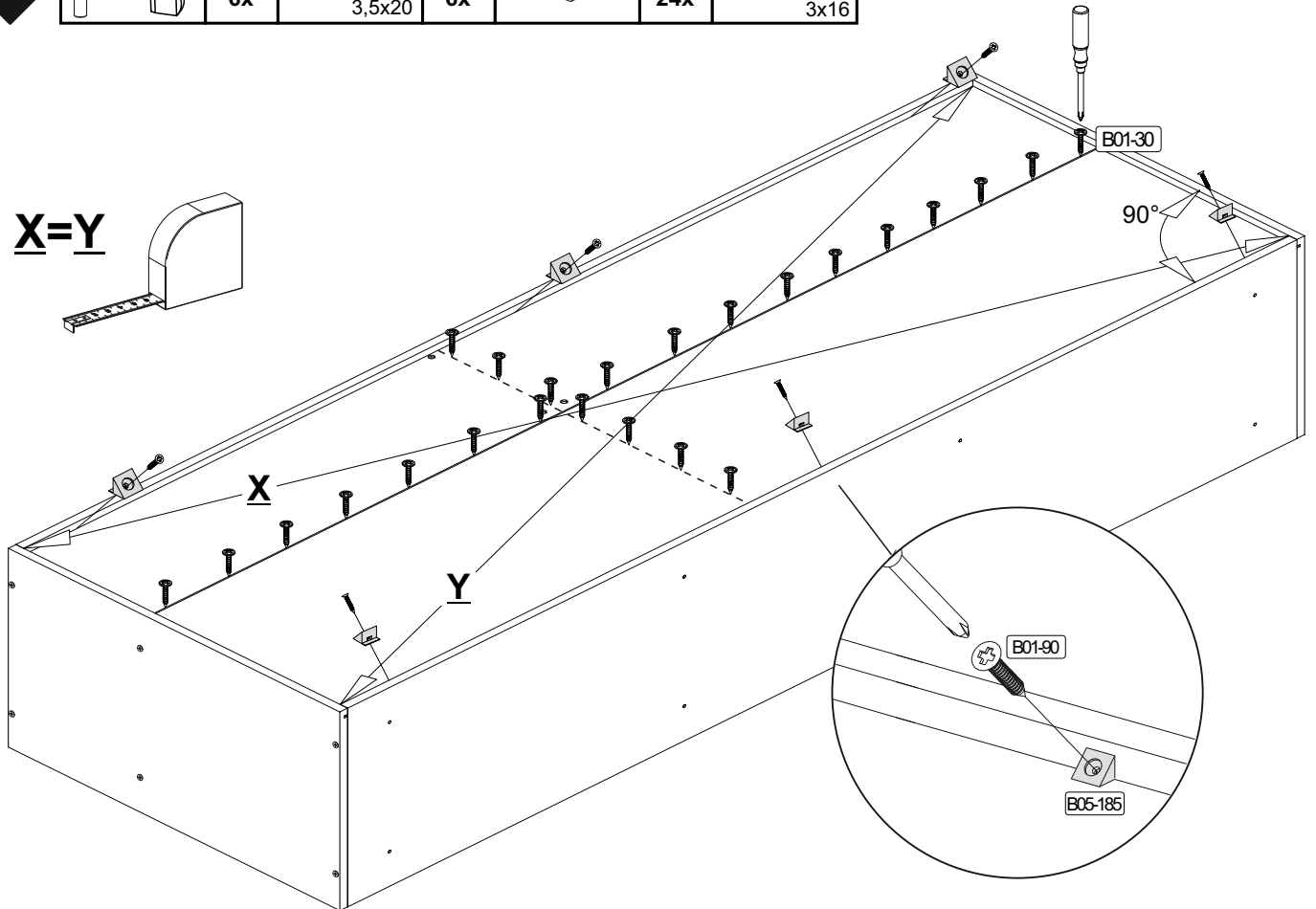
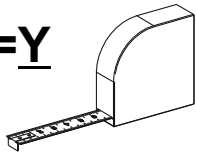

10



X = Y



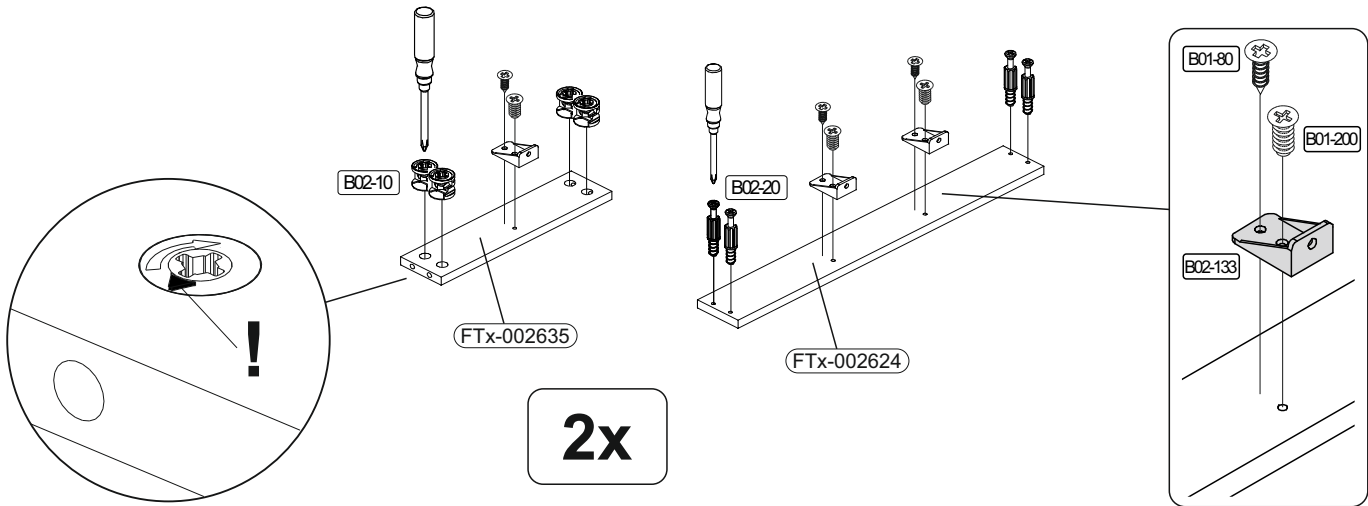

11

								
	8x	ø15x12mm	6x	6x	3,5x13	6x	8x	



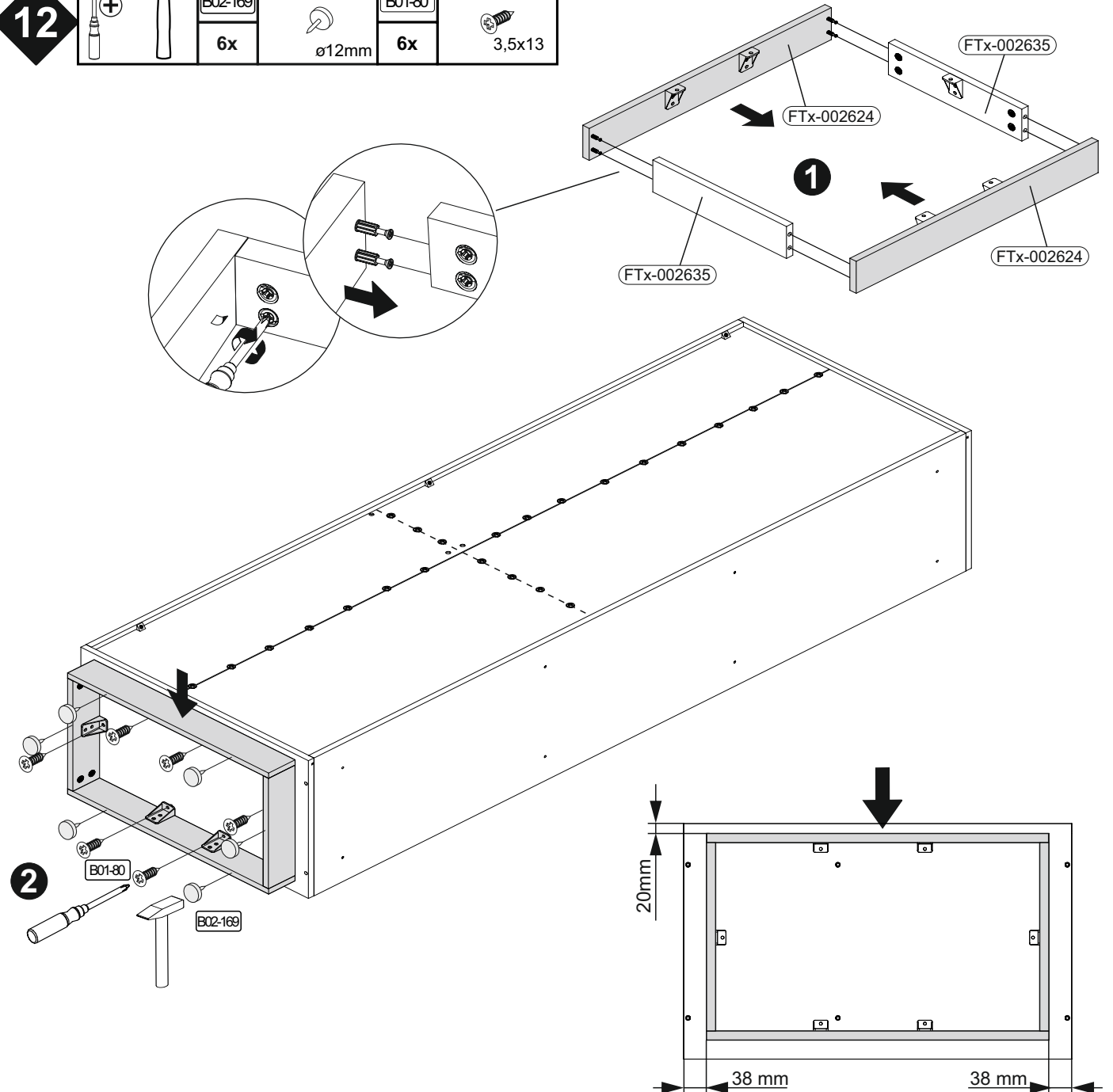

12

				
		6x	6x	3,5x13



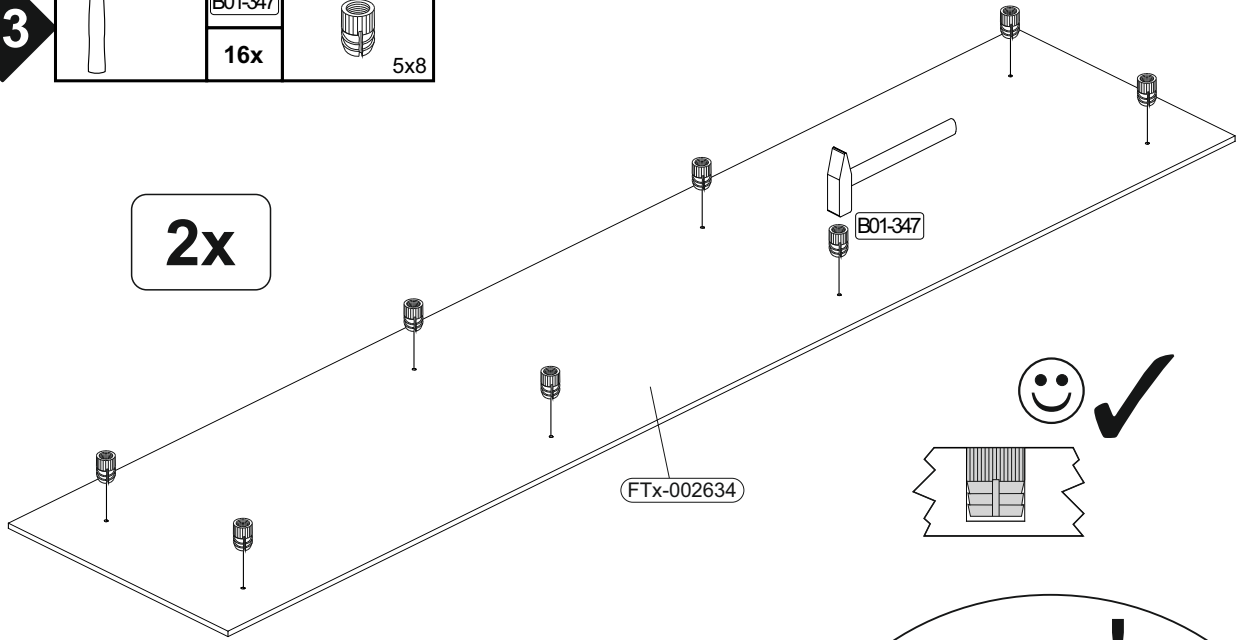

13

	B01-347	
	16x	5x8



14

	B01-190		B05-02	
	16x	M4x20	2x	ø20mm

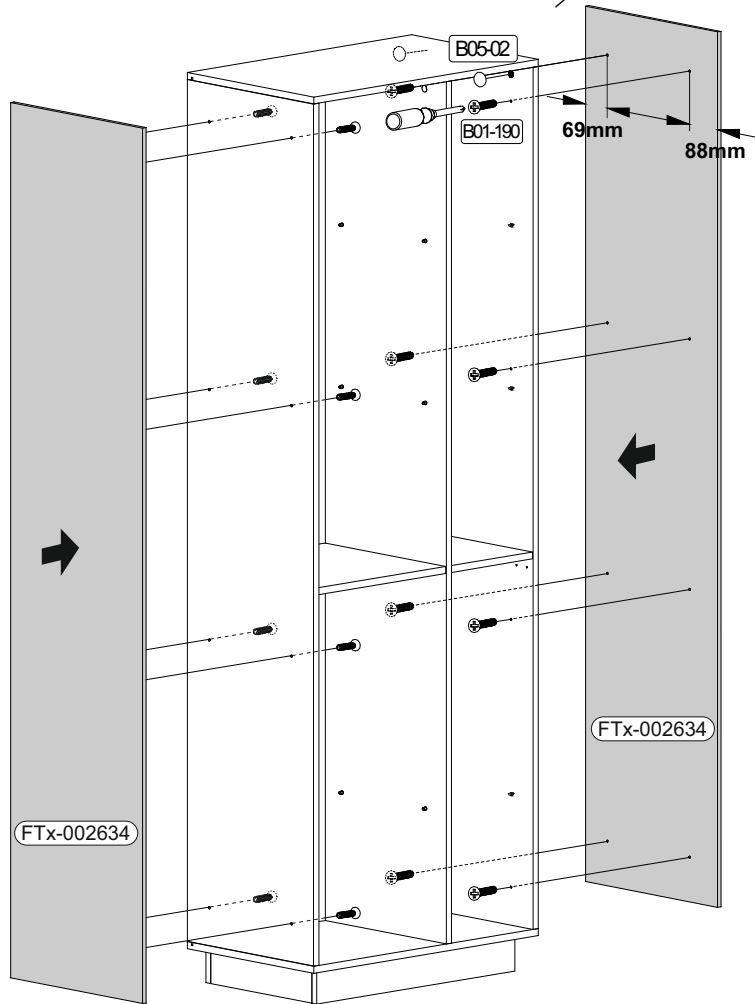
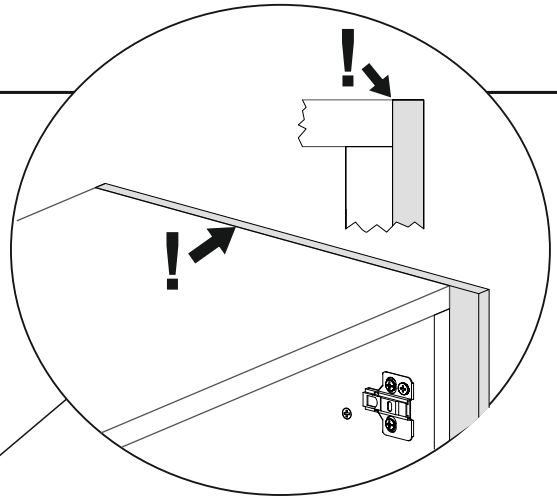

15

	B01-200	
3x		6,3x13

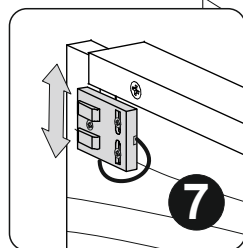
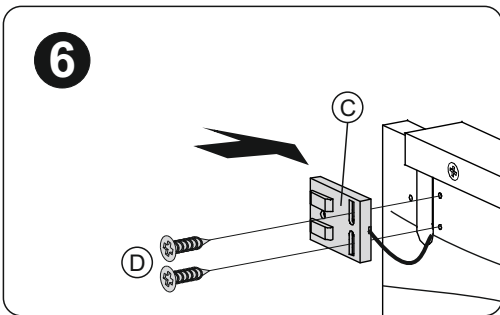
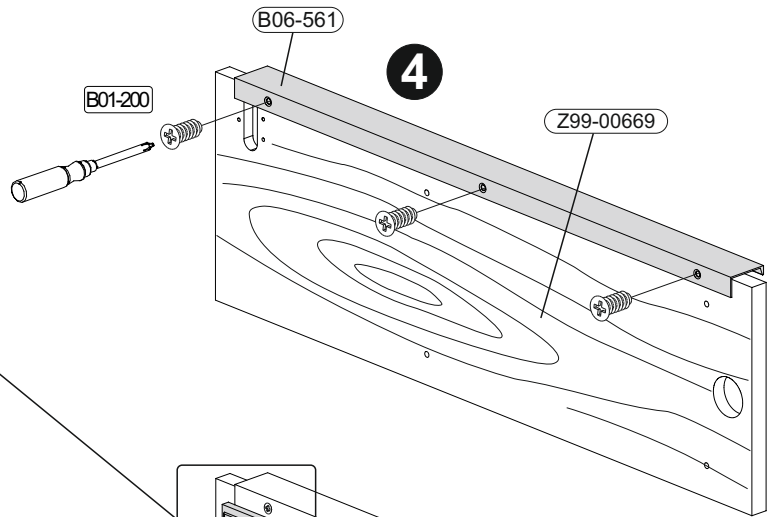
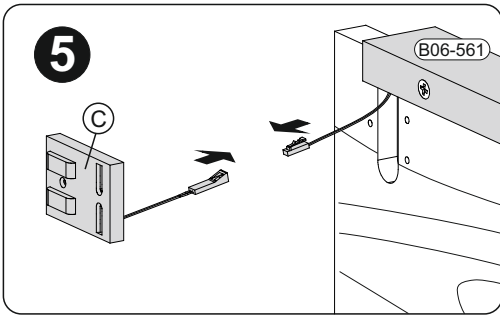
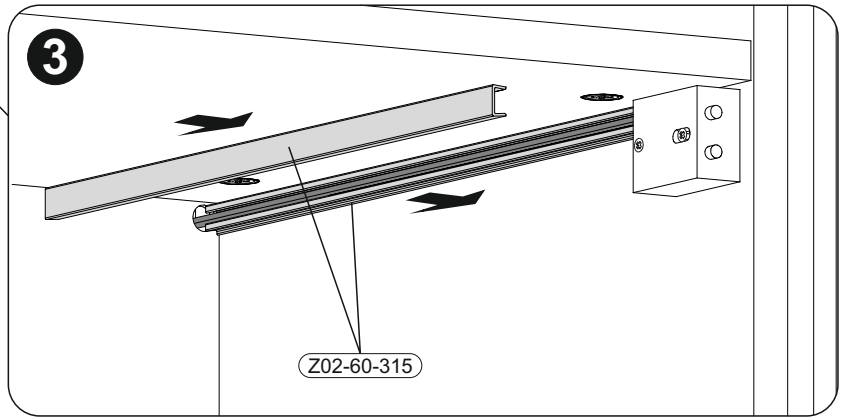
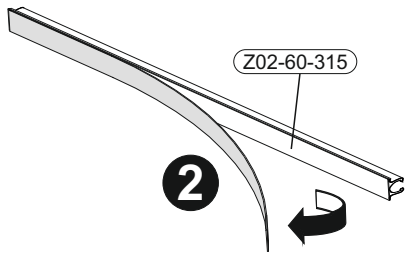
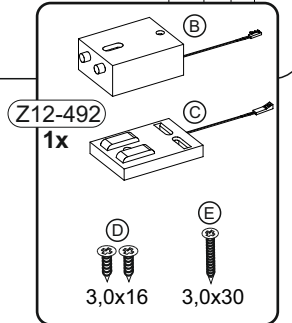
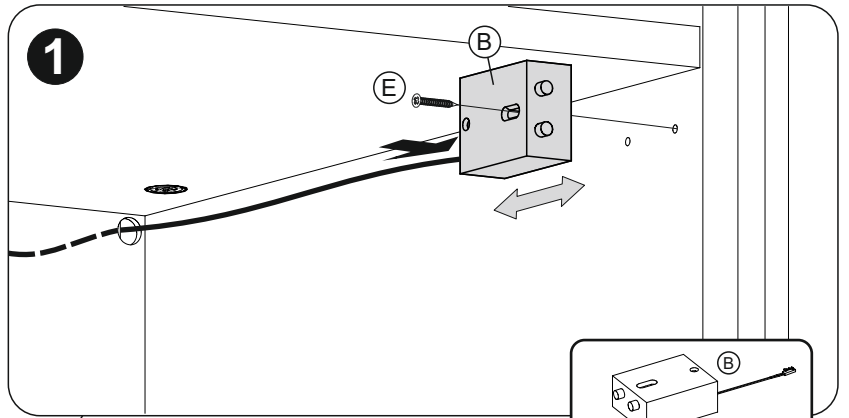
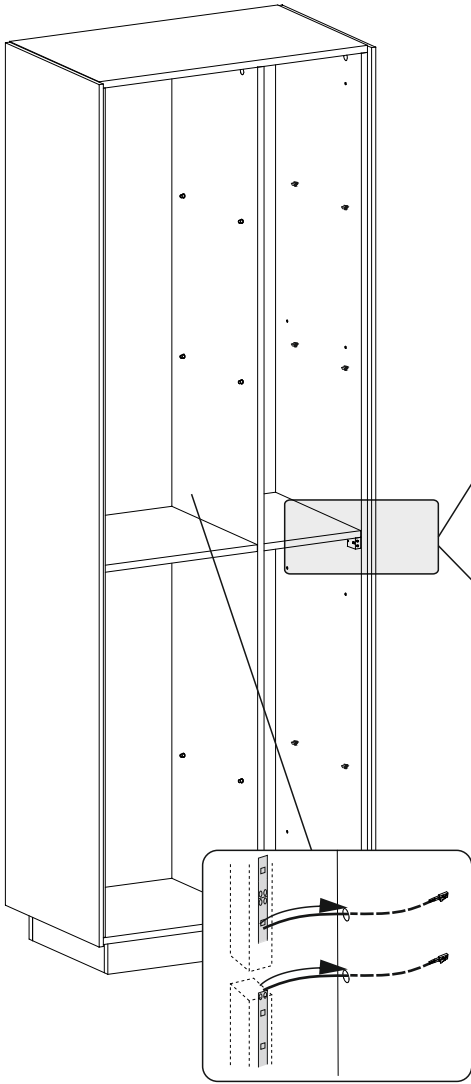

16

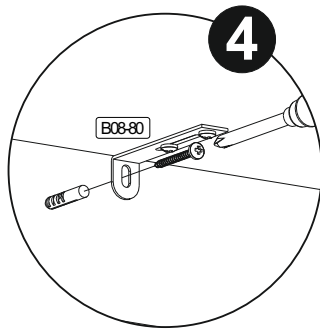
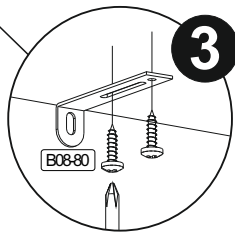
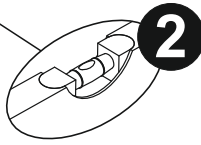
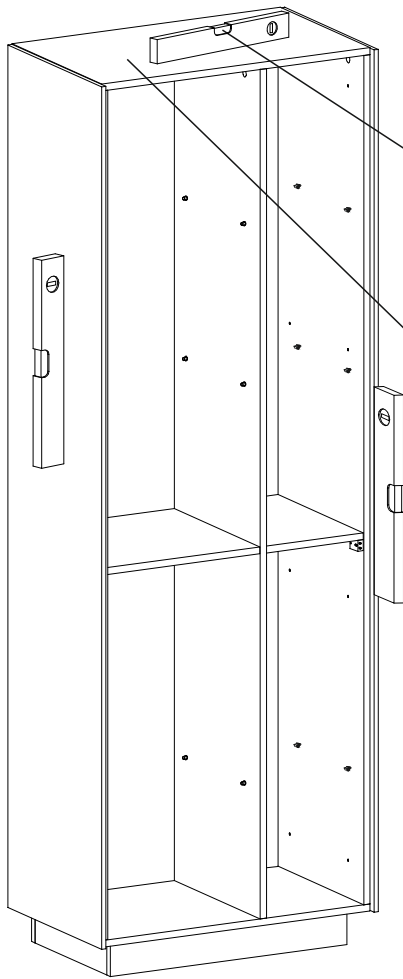
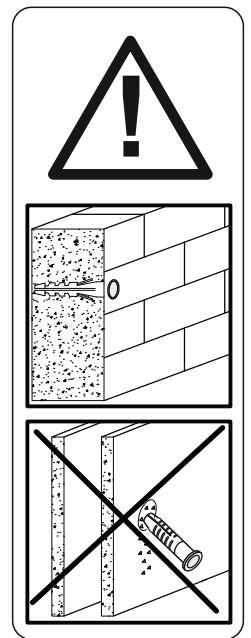
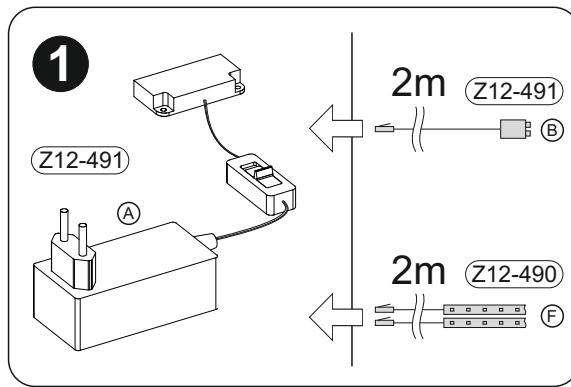
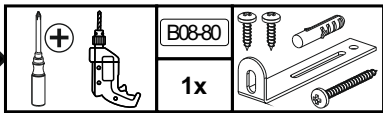

Achtung • Attention • Attenzione • Opgelet • Uwaga • Pozor • Figelem • Atenție • Dikkat • Внимание • Fara • Vaara • Fare • Peligro	
(D)	Wandbefestigung dient als Kippschutz - unbedingt anbringen! Bei einigen Wandtypen kann ein Spezialdübel erforderlich sein!
(GB)	The wall fastening serves to prevent tipping - be absolutely sure to mount it! For certain wall types, a special wall plug may be necessary!
(FR)	La fixation murale sert de protection contre le basculement – à installer impérativement ! Pour certains types de murs il faut des chevilles spéciales !
(TR)	Duvardaki sabitleme, devrilmeye karşı bir emniyet tedbiridir ve mutlaka monte edilmelidir! Bazı duvar tiplerinde bunun için özel bir dübel gerekli olabilir!
(IT)	Il fissaggio alla parete serve da protezione anti-ribaltamento – attaccarla assolutamente! Per alcune strutture di parete può essere necessario un tassello speciale!
(NL)	Bevestiging aan de muur dient als kantelbescherming – zeker en vast bevestigen! Bij enkele muurtypes is een speciale plug misschien vereist!
(RU)	Обязательно установите крепление на стене во избежание опрокидывания! Для некоторых типов стен может потребоваться специальный дюбель!
(CZ)	Montáž na stěnu slouží jako ochrana proti převrnutí – bezpodmínečně umístěte! U některých typů stěn může být zapotřebí speciální hmoždinka!
(HU)	A terméket a falhoz kel rögzíteni, különben az felborulhat! Egyes faltípusoknál speciális tiplit kell használni!
(RO)	Sistemul de fixare la perete serve ca protecție la răsturnare - de montat obligatoriu! Pentru unele tipuri de pereți este posibil să fie necesar un diblu special!
(PL)	Mocowanie do ściany jest jednocześnie zabezpieczeniem przed przewróceniem – koniecznie zamontować! Do niektórych rodzajów ścian koniecznie zastosować specjalne kołki mocujące.
(SWE)	Väggmontering fungerar som anti-lutningskydd - det är viktigt att fästa det! En speciell plugg kan behövas för vissa väggtyper!
(FIN)	Seinäkiinnitys toimii kaatumista estävänä suojana - se on ehdottomasti kiinnitettävä! Joihinkin seinätyypeihin voidaan tarvita erityistappi!
(NOR)	Veggmontering fungerer som anti-vippebeskyttelse - det er viktig å feste det! En spesiell dyvel kan være nødvendig for noen veggtyper!
(DAN)	Vægmontering fungerer som anti-vip beskyttelse - det er vigtigt at fastgøre det! En speciel dyvel kan være påkrævet til nogle vægtyper!
(SK)	Upevnenie na stenu slúži ako ochrana proti prevráteniu – bezpodmienečne použite! Pre niektoré druhy stien môže byť potrebná špeciálna hmoždinka!
(ES)	El montaje en la pared sirve como protección antivuelco: ¡es imprescindible fijarlo! ¡Es posible que se requiera una espiga especial para algunos tipos de paredes!

17

	B01-80		B03-01		B01-200		B02-144	
	6x	3,5x13	3x		4x	6,3x13	2x	

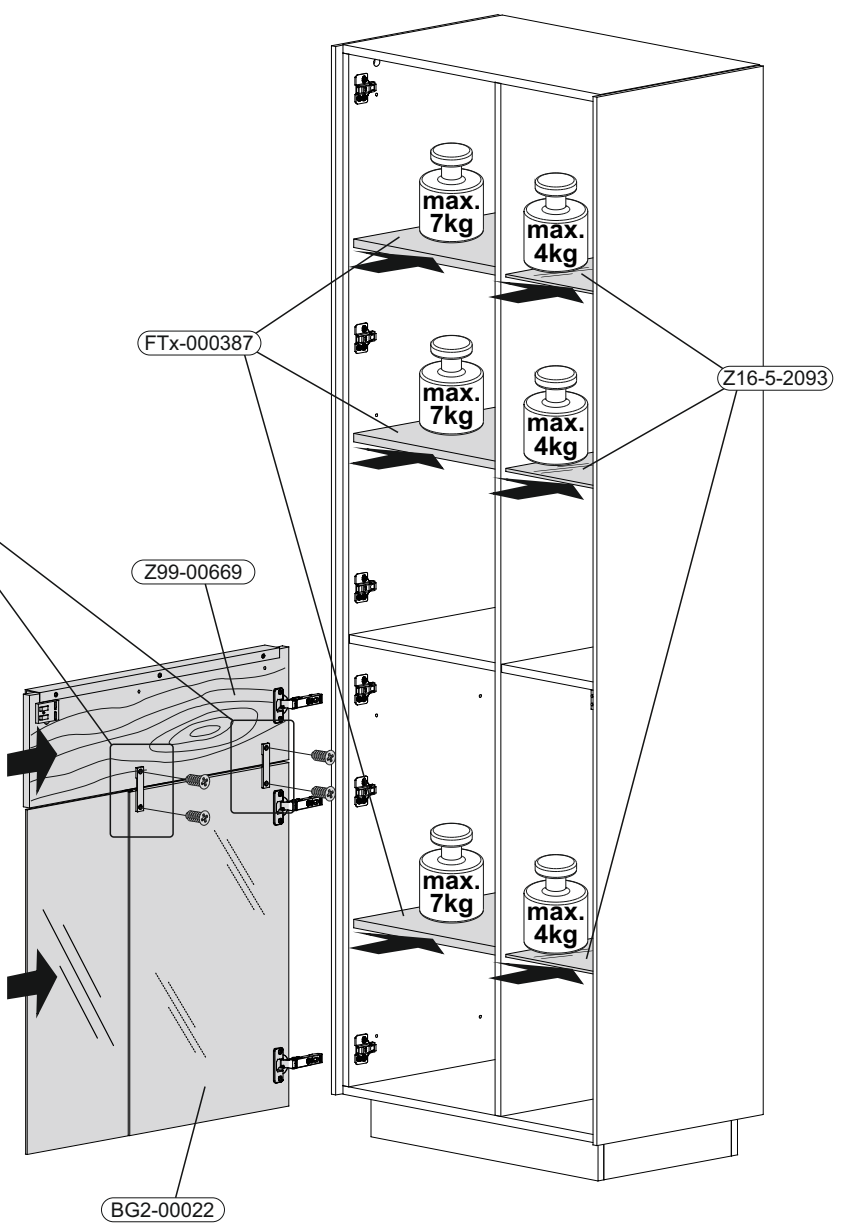
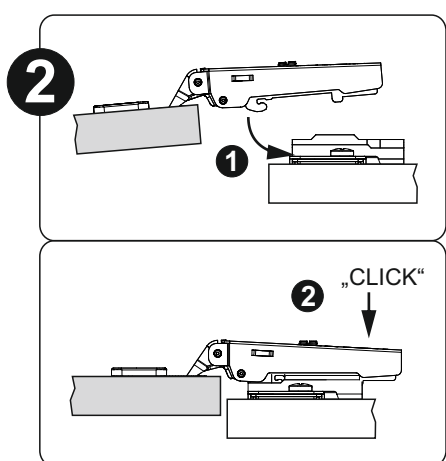
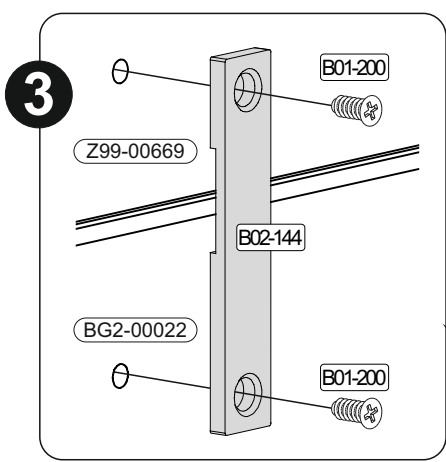
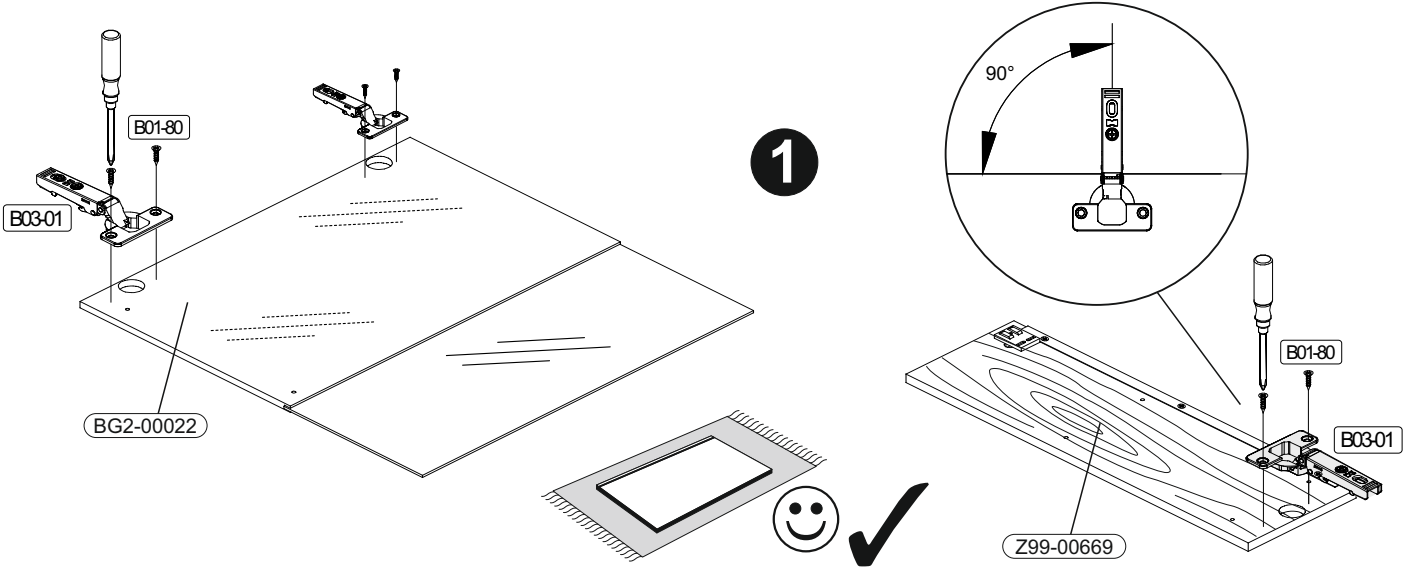

18

	B01-80		B03-01		B01-200		B02-144		B03-134	
	6x	3,5x13	3x		4x	6,3x13	2x		9x	

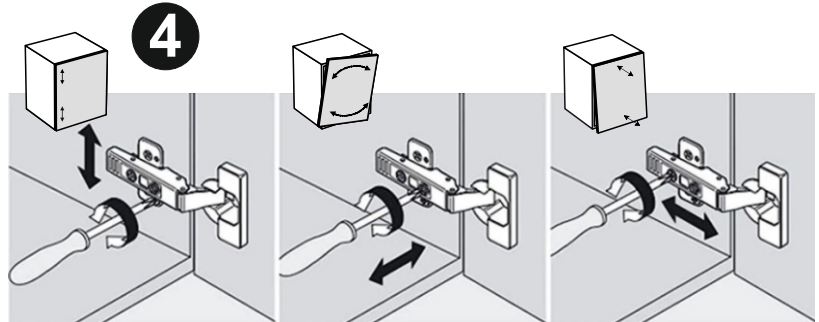
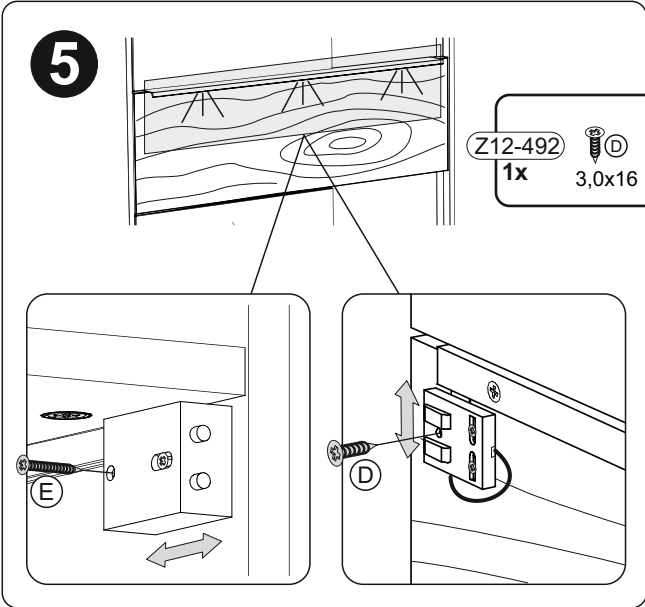
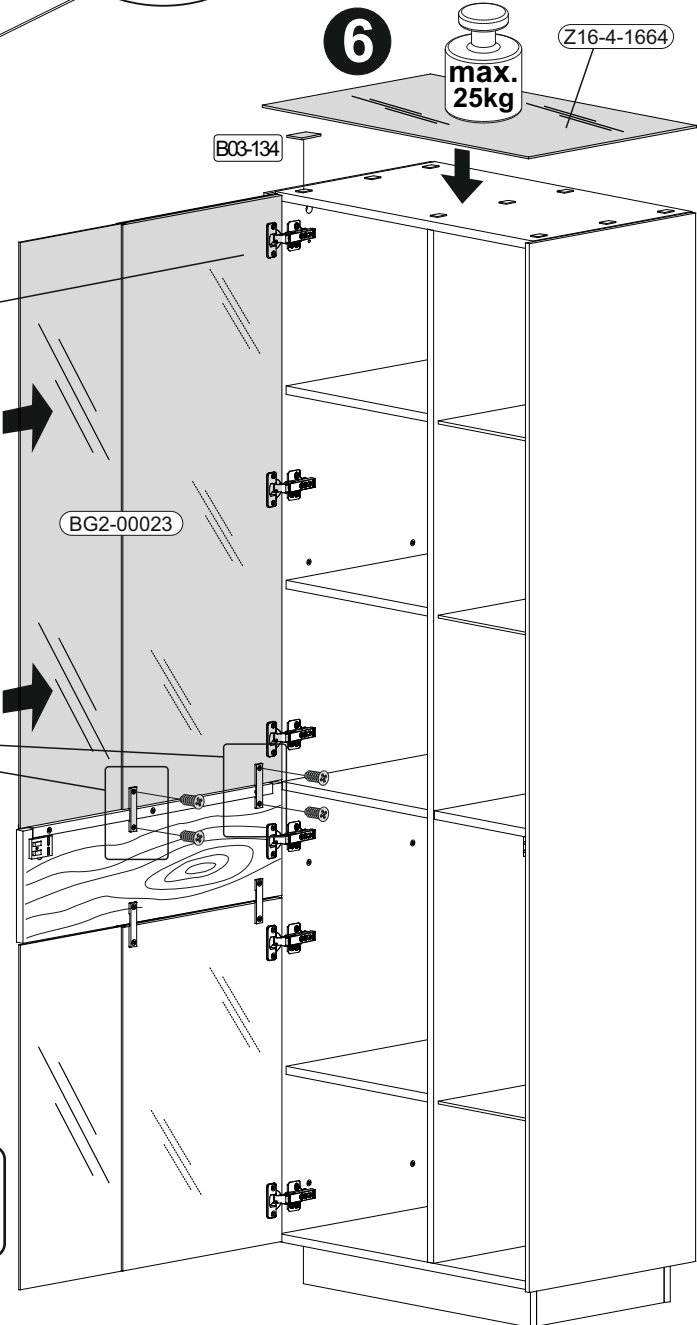
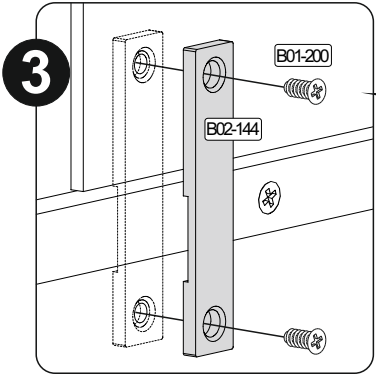
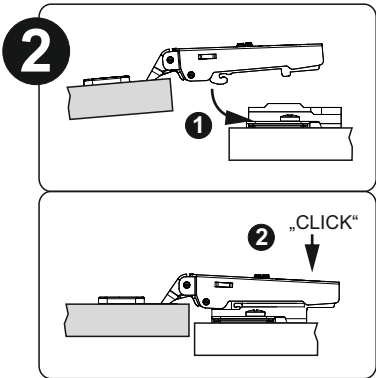
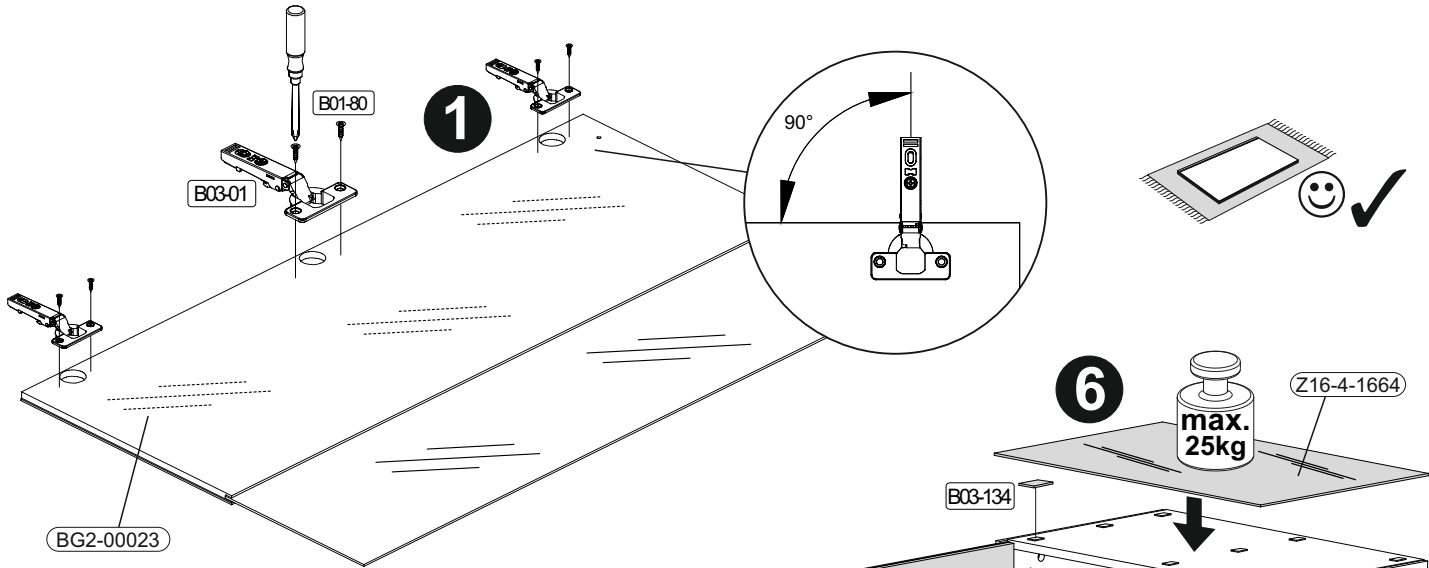

Z12-492
1x
3,0x16 3,0x30